



Beta Three

CSR215A

THEATER SURROUNDING SPEAKER

USER'S MANUAL

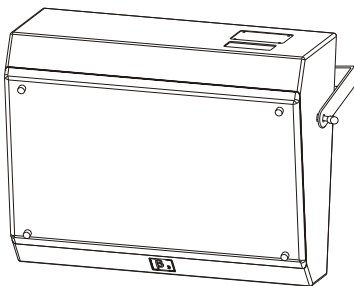

ED-B3-MA-051111-003



Features:

■ **Two transducers two way phase-inversed surrounding cinema speaker, professional high efficient transducers. Computer simulating design.**



- Two transducers two way full range
- High SPL, high sensitivity
- One 15" big power woofer
- One compression driver with 75mm titanium diaphragm
- Built-in electronic protection crossover
- (50-100)° × 55° wide dispersion can get the wider covering
- Computer simulating design provide very good Frequency response and phase feature
- Very convenient walling installation mode
- Suitable for THX,DTS and other multi-channel surrounding sound reinforcement in cinema
- Suitable for big/mid cinema audio system
- Can work with β 3 CSB218A,CS3412A,CS3415A when used for high quality music replaying

Specifications:

Transducers	Bass: 15"×1; Treb: φ75mm×1
Frequency response(-3dB/-10dB)	44Hz-15KHz/38Hz-20KHz
Sensitivity(1m/1W)	98dB
Xover point	2KHz
Dispersion(H×V)	(50-100)° × 55°
Power(RMS)	500W
Rated impedance	8 Ohm
DC impedance	5.3 Ohm
THD	<3%
Input	Spring clip
Net weight	34.5Kg
Gross weight	39Kg
Dimensions(W×D×H)	775×321×495mm
Packing dimensions(W×D×H)	595×454×865mm

Cabinet Dimension:

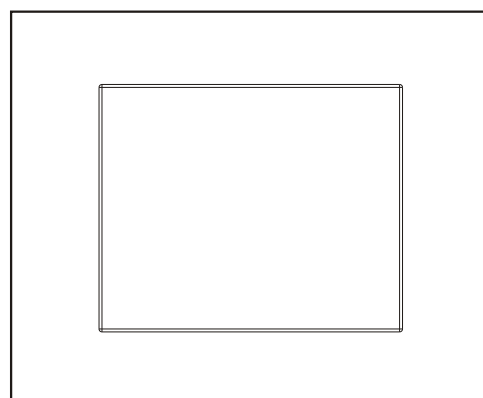
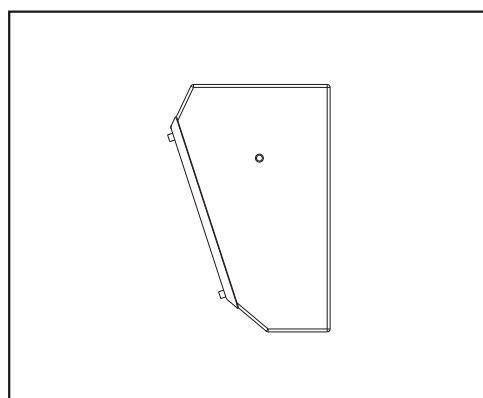
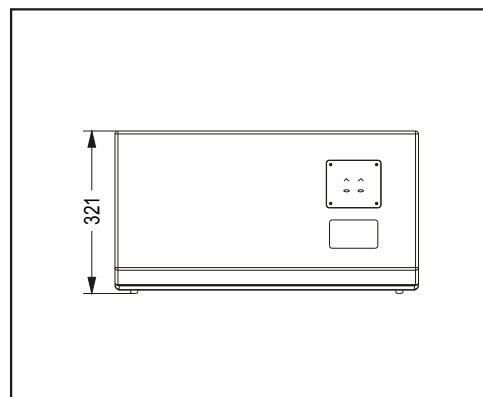
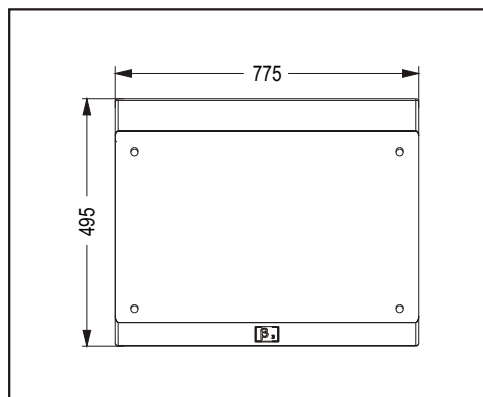

Installation drawing:

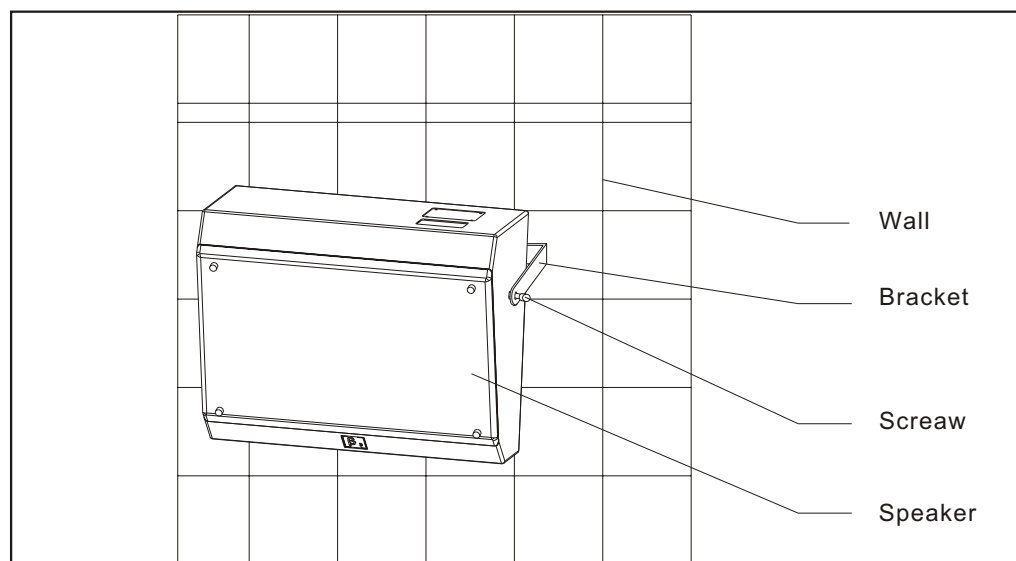

CSR215A
THEATER SURROUNDING SPEAKER